

## Installation and Removal Instructions



**WARNING! This device includes a possible pinch point. Always de-energize the device and use proper lock-out/tag-out procedures prior to servicing the device. Failure to do so may result in serious injury.**

If ordered with the JVL motor the Electric Vertical Toggle Clamp will be delivered with the linear actuator and motor pre-installed. To disassemble the clamp or reposition the motor, please refer to the instructions provided below to prevent damage to the unit. To assemble your own motor to the device, see "Stepper Motor Installation" instructions below.

### Linear Actuator Removal

1. Remove Covers.
2. Carefully remove bushings and pin from Rod End.
3. Remove the nylon-tipped set screw in the Clamp Body.
4. Unscrew the Linear Actuator.
5. Unscrew and remove the Rod End from the Linear Actuator.

### Linear Actuator Installation

1. Screw the Rod End onto the Linear Actuator.
2. Ensure threads are dry and free of any debris, then carefully thread the Linear Actuator clockwise into the Clamp Body. Stop when any more than a light hand force is required to continue.
3. If needed, rotate the Actuator counterclockwise to the desired position.
4. Install the provided nylon-tipped set screw in the rear counterbored hole in the Clamp Body. Torque until the nylon tip is compressed. The actuator is now secured in the Clamp Body.
5. Position the Rod End and Cam such that the hole through the Rod End aligns with the slot in the Cam.
6. Install the Pin through the Cam slot and Rod End hole.
7. Install one bronze bushing on either end of the pin and slide them into the Cam slots.
8. Install one PEEK bushing on either end of the pin. These will ride in the slots on the insides of the Covers.
9. Bolt the Covers back in place, starting with the Shoulder Screw, ensuring the PEEK bushings are in either Cover's guide slots.

**WARNING: DO NOT OVERTIGHTEN THE LINEAR ACTUATOR.** Doing so could potentially cause the actuator to disassemble and become lodged within the clamp body. Only apply slight hand torque and tighten in place with provided set screw.

### Stepper Motor Removal

1. Use an M2.5 hex key to loosen and remove the set screw from the shaft collar. The shaft collar is accessible through the two holes in the side of the actuator body.
2. Remove the (4) socket head cap screws that attach the linear actuator to the motor.
3. Separate the motor from the linear actuator.

### Stepper Motor Installation

If a motor other than the JVL motor sold by Carr Lane Mfg. is being installed, review step 4 prior to beginning installation.

1. Slide the 5mm motor shaft into the linear actuator clamp collar.
2. Use the M2.5 hex key to tighten the set screw into the clamp collar, securing the motor in place.
3. Attach the motor to the linear actuator by installing the (4) socket head cap screws. Make sure they are tightened securely to ensure the proper functioning of the motor and actuator.
4. NOTE: If a motor other than the JVL motor is being used, please confirm that the controller/driver supports sensor-less homing. In the absence of this feature, it is necessary to procure a sensor such as a reed or solid-state switch to ensure accurate positioning.

# Electric Vertical Toggle Clamp



**CLM-20x-EVTC**

CLM-200-EVTC - No motor  
CLM-201-EVTC - Motor installed

### Material

| Description                   | Material   |
|-------------------------------|--|
| Clamp Covers, Body, & Spacer  | Aluminum   |
| Clamp Cam, Link, & Rod End    | Tool Steel   |
| Cam Dowel Pins & Cover Screws | Stainless Steel  |
| Cam Bushings                  | Aluminum-Bronze  |
| Cover Bushings                | PEEK   |
| Clamp Arm                     | Steel, Black Oxide                                     |
| Arm Dowel Pin                 | Steel, Black Oxide                                     |
| Shoulder Screw                | Alloy Steel  |
| Linear Actuator               | Stainless Steel (see vendor data sheet for full specs) |
| Motor                         | See vendor data sheet                                  |

### Accessories

| Part Number | Description          | Product Image   |
|-------------|----------------------|---|
| CL-1-HVTC-A | Weld on Clamping Arm |  |

## Product Description

The Electric Toggle Clamp features an advanced JVL NEMA 17 profile integrated ServoStep Motor providing unparalleled control and accuracy of the clamping arm throughout the clamping stroke. This integrated motor comes with current protection, allowing for sensor-free homing and operation. Its rugged construction and high-grade components guarantee outstanding durability and reliability, ensuring maximum performance during extended periods of use. Like all Toggle Clamps the Electric Toggle Clamp uses an over-center locking principle known as a “toggle action.” Actuating the clamp first moves the mechanism into position, then applies clamping force by compressing or stretching the linkage elements after contacting the workpiece, then positively locks the mechanism by moving the toggle action’s center pivot past the centerline of the other two pivots, against a stop making this electric clamp is incredibly versatile. Boasting a compact design and adaptable mounting options that make it suitable for a wide range of applications, including CNC machining, woodworking, metalworking, welding, and more.

The clamp is also available without a motor, enabling the use of any NEMA 17 motor. This flexibility suits virtually any specific need or preference, further enhancing the versatility and adaptability of this innovative clamping solution.

## Technical Drawing

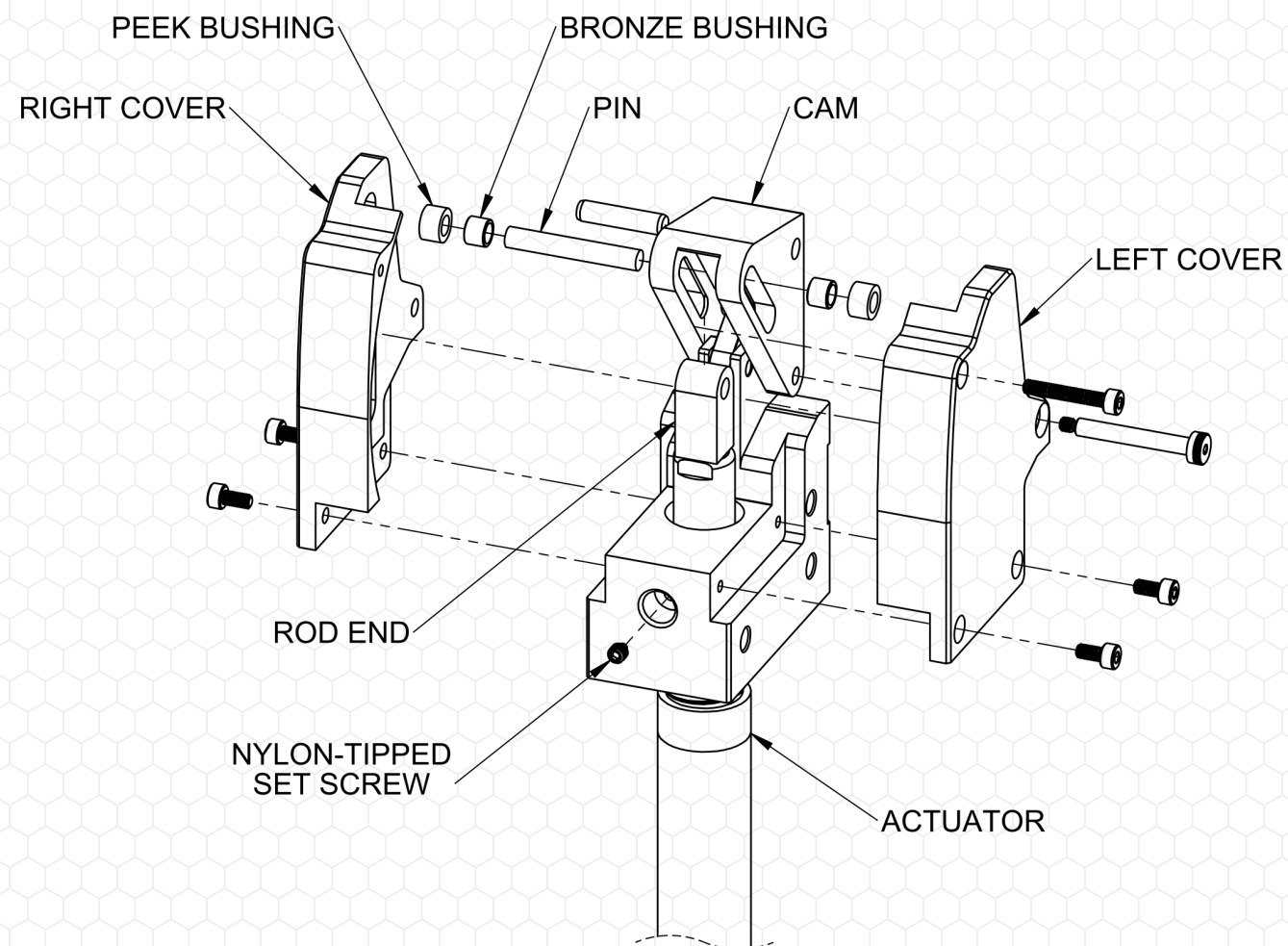

| PART NO.     | MOTOR SHAFT DIA | MOTOR SIZE | HOLDING CAPACITY    | MOTOR INCLUDED | MAX EFFECTIVE FORCE @ X |
|--------------|-----------------|------------|---------------------|----------------|-------------------------|
| CLM-200-EVTC | 5mm             | NEMA 17    | 500 lbs (226.80 Nm) | NO             | 200 lbs (90.72 Nm)      |
| CLM-201-EVTC | 5mm             | NEMA 17    | 500 lbs (226.80 Nm) | YES            | 200 lbs (90.72 Nm)      |

The maximum effective clamping force will vary depending on factors such as the spindle and distance from body.

## Motor Information

|                        |                                     |
|------------------------|-------------------------------------|
| Manufacturer           | JVL                                 |
| Website                | JVL MIS Motors                      |
| Model                  | MIS173S16Q5H266                     |
| Supply Voltage Driver  | 7-72V DC                            |
| Supply Control & IO    | 7-28V DC                            |
| Holding Torque         | 0.40 Nm                             |
| Nominal Speed Range    | 0-3000 RPM                          |
| Shaft Diameter         | 5mm                                 |
| Integrated PLC Control | Input/Output Voltage Range 7-28V DC |
| User Manual            | EN, DE                              |
| Brochure               | Brochure                            |

## Programming Requirements

|                      |  |
|----------------------|--|
| Programming Software | <b>JVL MacTalk®</b> This software is <b>REQUIRED</b> to program the MIS173 motor and is <b>NOT</b> included. |
| Programming Cable    | USB to RS485 and JVL M12M5T05  |

## Linear Actuator Information

|              |   |
|--------------|---|
| Manufacturer | Tolomatic   |
| Website      | ToloMatic – ERD10   |
| Model        | ERD10-BNM05SM70LMIST1   |
| Stroke       | 70mm  |
| Max Thrust   | 100 lbf (445 N) – <i>If a motor other than the recommended JVL motor is used maximum thrust will be dependent on motor torque. Contact Carr Lane Manufacturing with torque data for assistance on determining maximum thrust.</i> |